

## Appendix A: TROPOMI description

### Introduction

TROPOMI (TROPOspheric Monitoring Instrument) is a satellite instrument for remote sensing of the Earth's atmosphere. Its primary goal is to be sensitive in the troposphere down to the boundary layer/Earth's surface in order to quantify emissions and transport of anthropogenic and natural trace gases and aerosols, which impact air quality and climate.

TROPOMI will measure the main tropospheric pollutants ( $O_3$ ,  $NO_2$ , CO, formaldehyde (HCHO) and  $SO_2$ ) and two major climate gases (tropospheric  $O_3$  and methane ( $CH_4$ )). In addition, it will measure important parameters of aerosols (aerosol scattering, absorption and type identification), which play a key role in climate change as well as in tropospheric pollution. The main instrument requirements for the TROPOMI instrument have been derived to fulfil the user requirements for the above-mentioned species.

TROPOMI is a Dutch initiative building upon the successes of SCIAMACHY and OMI. This new instrument combines all good things of the previous instruments and improves on most specifications. The instrument is designed by TNO and Dutch Space in The Netherlands, who were also involved to great extent in TROPOMI's predecessors (OMI on NASA's EOS-Aura, launched in 2004 [Levelt et al, 2006]; SCIAMACHY on ESA-ENVISAT, launched in 2002 [Bovensmann et al, 1999]; GOME on ESA-ERS-2, launched in 1995 [Burrows et al, 1999]; and EUMETSAT MetOp, launched in 2006 [Callies et al, 2000]).

The design uses a modular approach, in order to be flexible to accommodate different requirements from the various missions it can fly on.

### Instrument overall description

TROPOMI is a nadir-viewing grating-based imaging spectrometer similar to OMI, with an additional optical channel based on the SCIAMACHY heritage. The instrument will measure both the Earth radiance and solar irradiance spectra, in combination yielding the reflectance spectrum that contains the information for retrieval of atmospheric trace gases. It has two dimensional detectors, which use one dimension to measure spectral information and the other dimension for the across-flight swath.

The special OMI-like telescope has a wide viewing angle that enables daily global coverage and that corresponds to a swath width of about 2600 km. The swath allows coverage of the complete globe in one day and at higher latitudes several observations per day as a result of orbit overlap. For a non-sun-synchronous, medium-inclination drifting orbit, the swath width is also about 2600 km and allows near-global daily coverage and unique diurnal time sampling with up to 5 daytime observations over mid-latitude regions (Europe, North- America, China). TROPOMI will have 140 ground pixels/swath, OMI has 60.

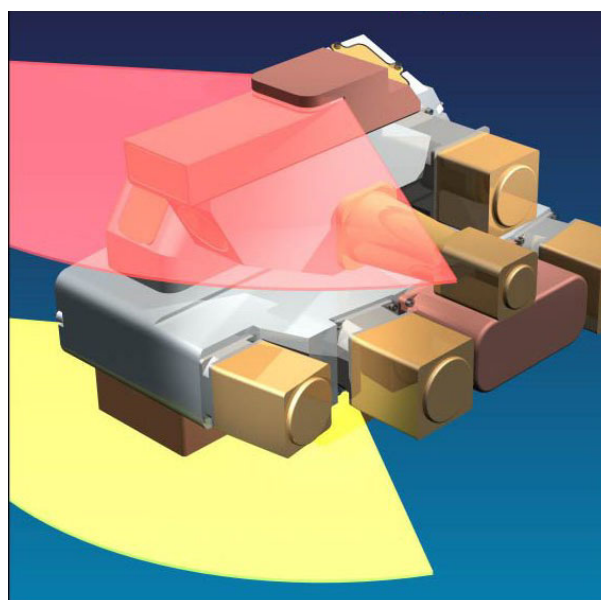

Fig. B1. CAD drawing of TROPOMI. At the bottom the UV-VIS-NIR module, on the top, the SWIR module.

TROPOMI covers the OMI wavelengths of 270 – 490 nm to measure O<sub>3</sub>, NO<sub>2</sub>, HCHO, SO<sub>2</sub>, cloud and aerosols parameters in three channels (UV1, UV2 and VIS). Compared to OMI, a NIR channel and a SWIR module are added (heritage from SCIAMACHY). The NIR-channel (710 – 775 nm) is used for improved cloud detection using the oxygen A-band. The SWIR module (2305 – 2385 nm) measures CO and CH<sub>4</sub> and forms a separate module because of its thermal requirements. The spectral resolution will be about 1.1 nm in the UV1 channel, about 0.45 nm in the UV2/VIS/NIR channels and 0.25 nm in the SWIR wavelength range. See Table A1 for the characteristics of the different channels.

**Table A1. Characteristics of the TROPOMI optical channels and their products.**

Optical channel	Full spectral range [nm]	Full performance range [nm]	Nadir ground pixel size [km <sup>2</sup> ]	Achievable S/N for minimum scenario <sup>(1)</sup>	Spectral resolution [nm] / and sampling ratio	Products <sup>(2)</sup>
UV1 <sup>(3)</sup>	270 – 320	270 – 310	40 × 40	100 (at 270 nm) - 1000 (at 310 nm)	1.1 / 4	<b>O<sub>3</sub></b>
UV2	295 – 380	310 – 370	10 × 10	1000	0.45 / 4	<b>O<sub>3</sub>, SO<sub>2</sub>, HCHO, BrO,</b> <i>OCIO</i>
VIS	360 – 495	370 – 490	10 × 10	1500	0.52 / 4	<b>NO<sub>2</sub>, aerosol properties,</b> <i>O<sub>2</sub>-O<sub>2</sub> cloud fraction / pressure, CHOCHO</i>
NIR	710 – 775	710 – 775	10 × 10	Absorption 100 Continuum 500	0.45 / 4	<b>O<sub>2</sub>-A cloud fraction,</b> <b>optical thickness and pressure,</b> <i>H<sub>2</sub>O, aerosol height</i>
SWIR	2305 – 2385	2314 – 2375	10 × 10	95	0.25 / 2	<b>CO, CH<sub>4</sub></b>

Notes: (1) The S/N is specified for a minimum scenario with a surface albedo of 2% (UV-VIS-NIR), and 5% (SWIR).

(2) The main products are **in bold**, lower priority products are in italics.

(3) The UV1 channel is meant for measurements of the stratosphere and upper troposphere and has relaxed spatial and spectral requirements.

A major improvement with respect to the SCIAMACHY and OMI capabilities is the reduced ground pixel size of TROPOMI. This not only improves the ability to locate sources and sinks of certain gases, but also significantly increases the number of cloud-free observations. The nadir ground pixel of TROPOMI is 10 × 10 km<sup>2</sup>. This value is relaxed to 40 × 40 km<sup>2</sup> for the UV1 channel, because the ground and the lower troposphere cannot be observed in this wavelength range and thus larger ground pixels can be used to meet the required signal-to-noise ratio. Using improved optics and detectors, TROPOMI will have signal-to-noise ratios that are typically a factor of two better than OMI. For SWIR the nadir ground pixel improves compared to SCIAMACHY from 120 × 30 km<sup>2</sup> for CO and 60 × 30 km<sup>2</sup> for CH<sub>4</sub> to 10 × 10 km<sup>2</sup>. In addition, the sensitivity per individual measurement is much improved (at least a factor 5 for CO).

### Development status

TROPOMI is designed to improve significantly on sensitivity and spatial resolution compared to OMI and especially to SCIAMACHY and GOME-2. This will be achieved by, amongst others:

- using improved CCD or CMOS detectors
- having separate UV1 and UV2 detectors instead of combing the UV image on a single CCD detector as in OMI
- using the OMI pushbroom imaging technique (measuring a full swath at the same time) for the SWIR channel instead of the scanning mirror concept of SCIAMACHY and GOME-2 (which performs only one single measurement at the time).

The SWIR channel is one the most challenging technical parts of the TROPOMI design. In order to realise pushbroom imaging technique in the SWIR within an acceptably sized instrument, new technologies are needed, in particular a so-called immersed grating. Therefore, a functionally flight

representative breadboard model of the SWIR channel has been designed [Hoogeveen et al, 2007] to test the performance and various critical components. These components are HgCdTe-based 2D CMOS detector, the on-board SWIR calibration LED, and in particular, the SRON/TNO developed silicon-based immersed grating that allows a strongly reduced instrument volume. Preliminary tests have demonstrated the feasibility of extending the OMI pushbroom observation strategy to the SWIR wavelength range.

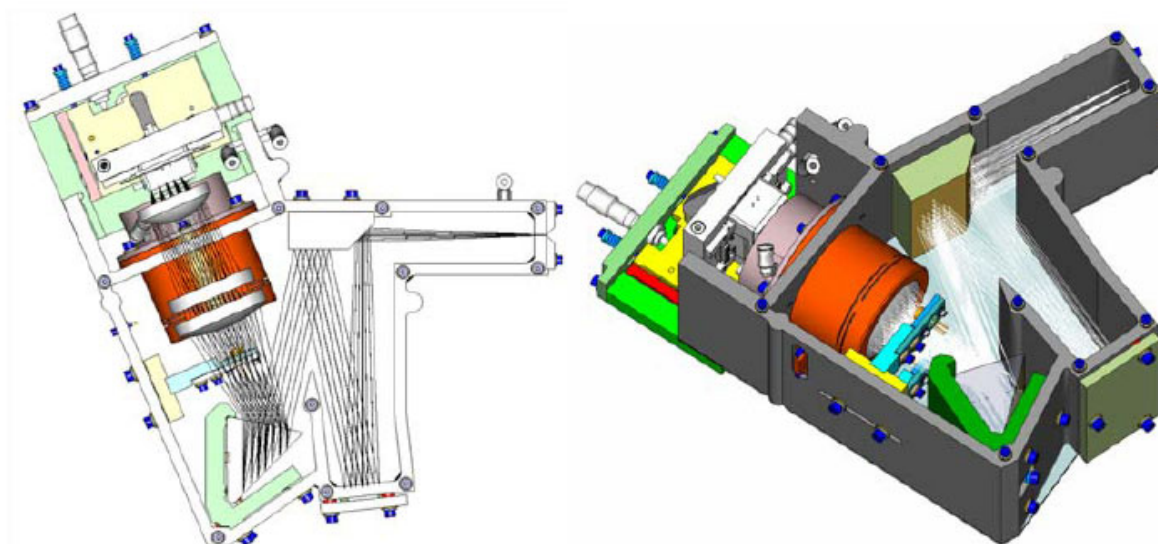

Fig. A2. Design of the TROPOMI-SWIR breadboard model (drawings courtesy of MECON BV)

## References

- Bovensmann, H., J.P. Burrows, M. Buchwitz, J. Frerick, S. Noel, V.V. Rozanov, K.V. Chance, A.P.H. Goede, *SCIAMACHY: mission objectives and measurement modes*, *J. Atmos. Sci.* **56**, 127-155 (1999).
- Burrows, J.P., M. Weber, M. Buchwitz, V. Rozanov, A. Ladstätter-Weissenmayer, A. Richter, R. De Beek, R. Hoogen, K. Bramstedt, K.W. Eichmann, M. Eisinger, and D. Perner, *The Global Ozone Monitoring Experiment (GOME): Mission Concept and First Scientific Results*, *J. Atm. Sci.*, **56**, 151-175, 1999.
- J. Callies, E. Corpaccioli, M. Eisinger, A. Hahne, A. Lefebvre, *GOME-2 - MetOp's Second Generation sensor for Operational Ozone Monitoring*, *ESA Bulletin*, **102**, 2000
- R.W.M. Hoogeveen, R.T. Jongma, P.J.J. Tol, A. Gloudemans, I. Aben, J. de Vries, H. Visser, E. Boslooper, M. Dobber, P.F. Levelt, *Breadboarding activities of the TROPOMI-SWIR module*, *Proc SPIE*, **6744**, 2007
- Levelt, P.F., G.H.J. van den Oord, M.R. Dobber, A. Mälkki, H. Visser, J. de Vries, P. Stammes, J. Lundell and H. Saari, *The Ozone Monitoring Instrument*, *IEEE Trans. Geo. Rem. Sens.*, 2006, Vol. **44**, No. 5, 1093-1101, doi:10.1109/TGRS.2006.872333.